

UNCONTROLLED IF PRINTED; CONTROLLED COPY LOCATED IN IQMS DOCUMENT CONTROL

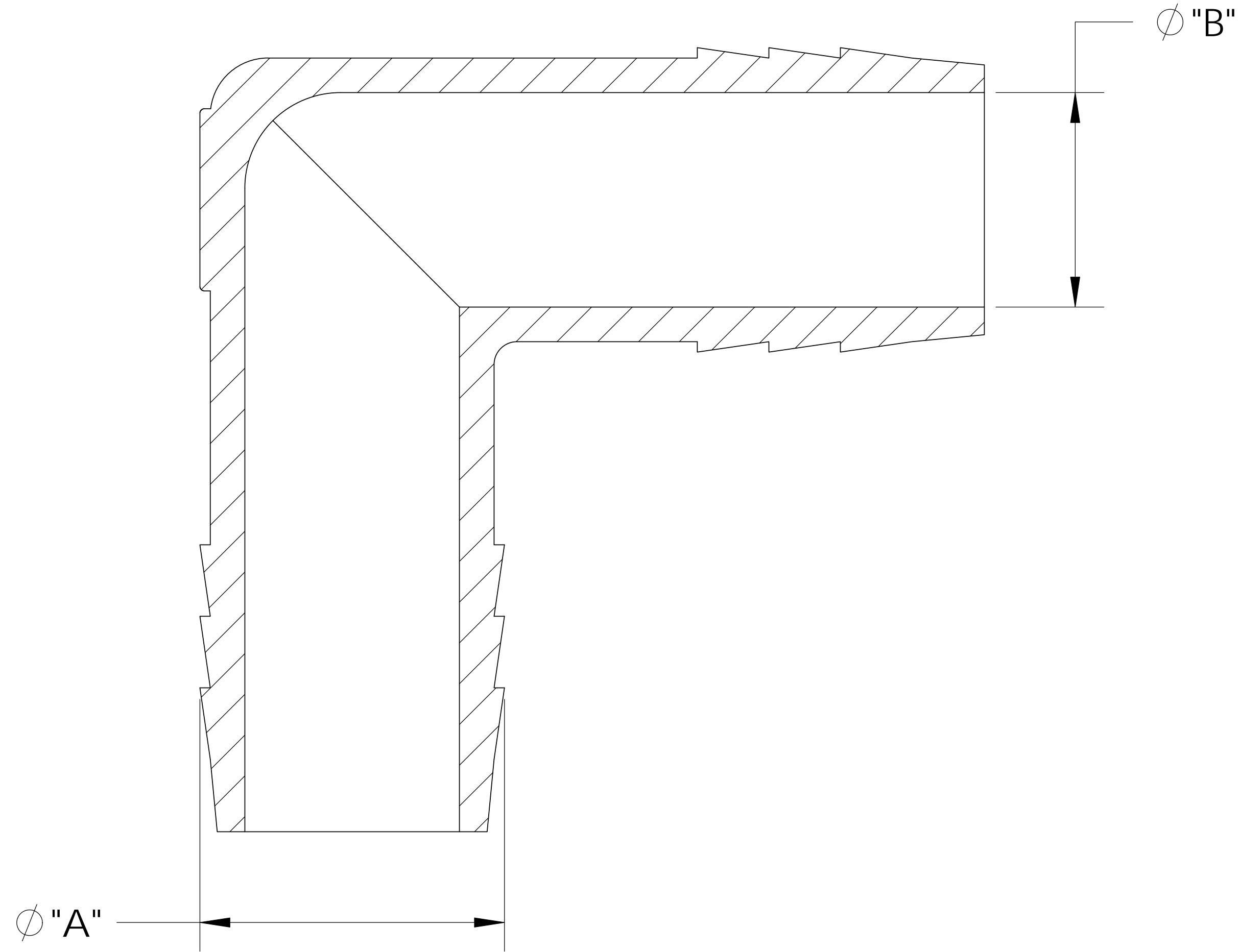

SECTION A-A

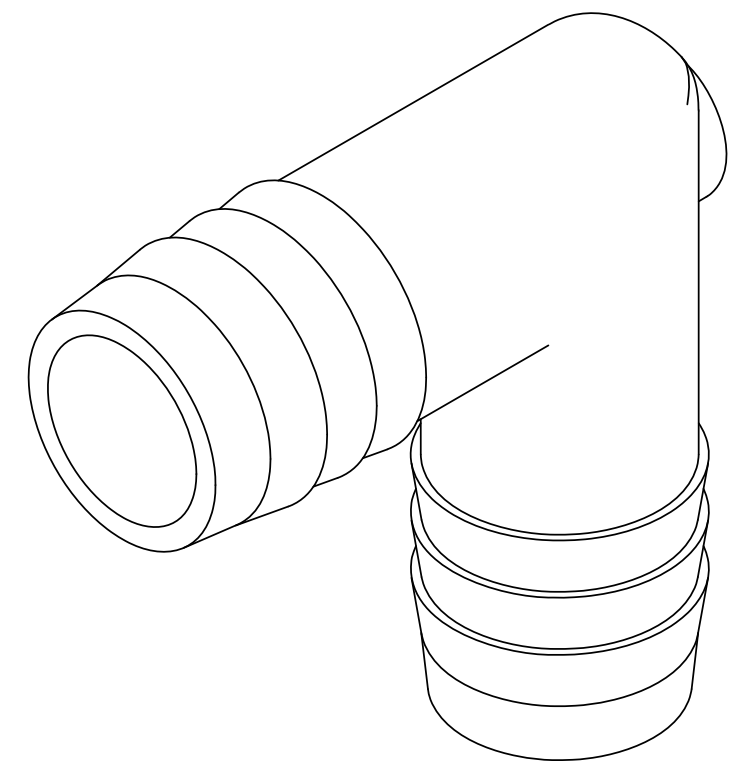
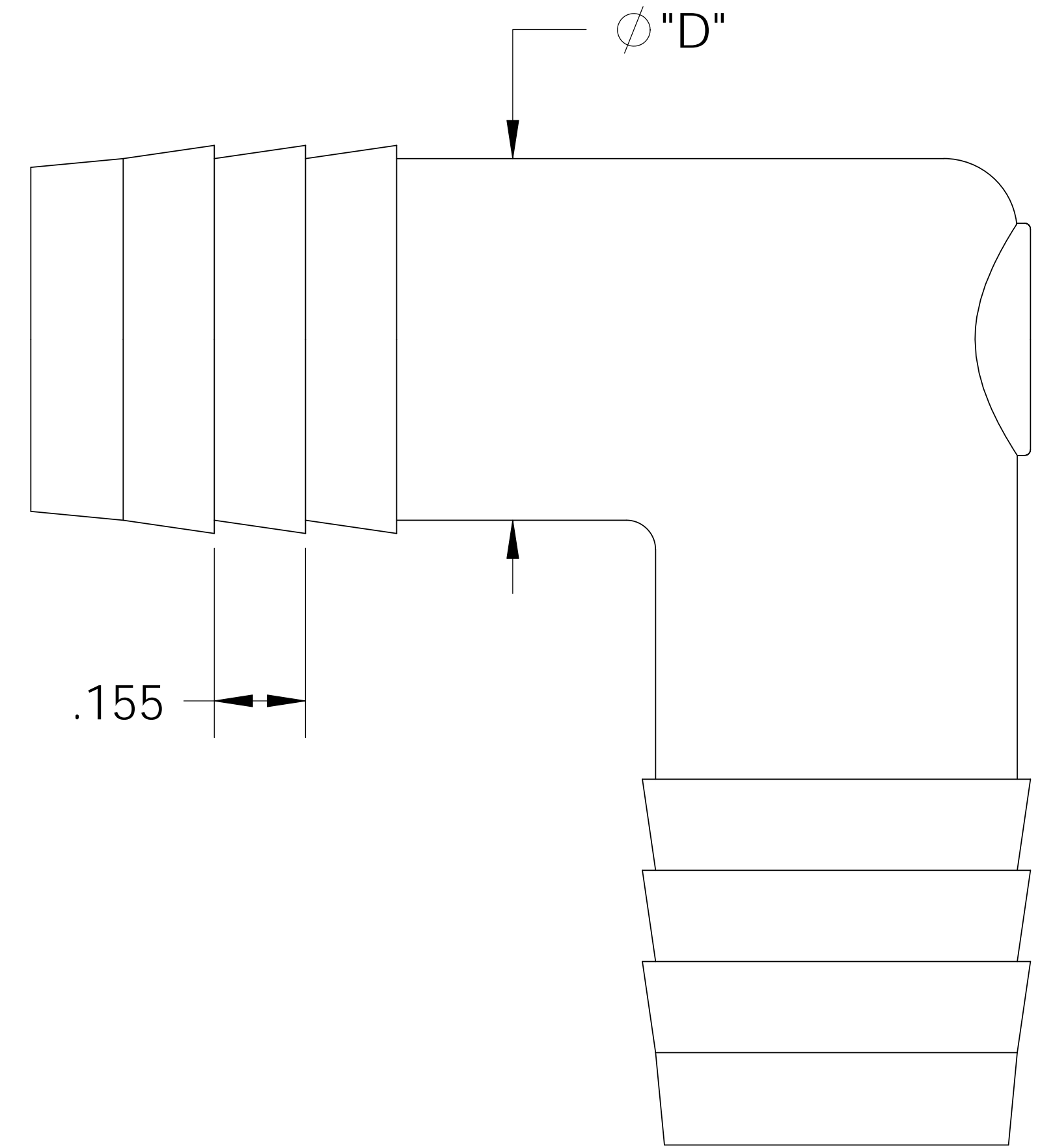
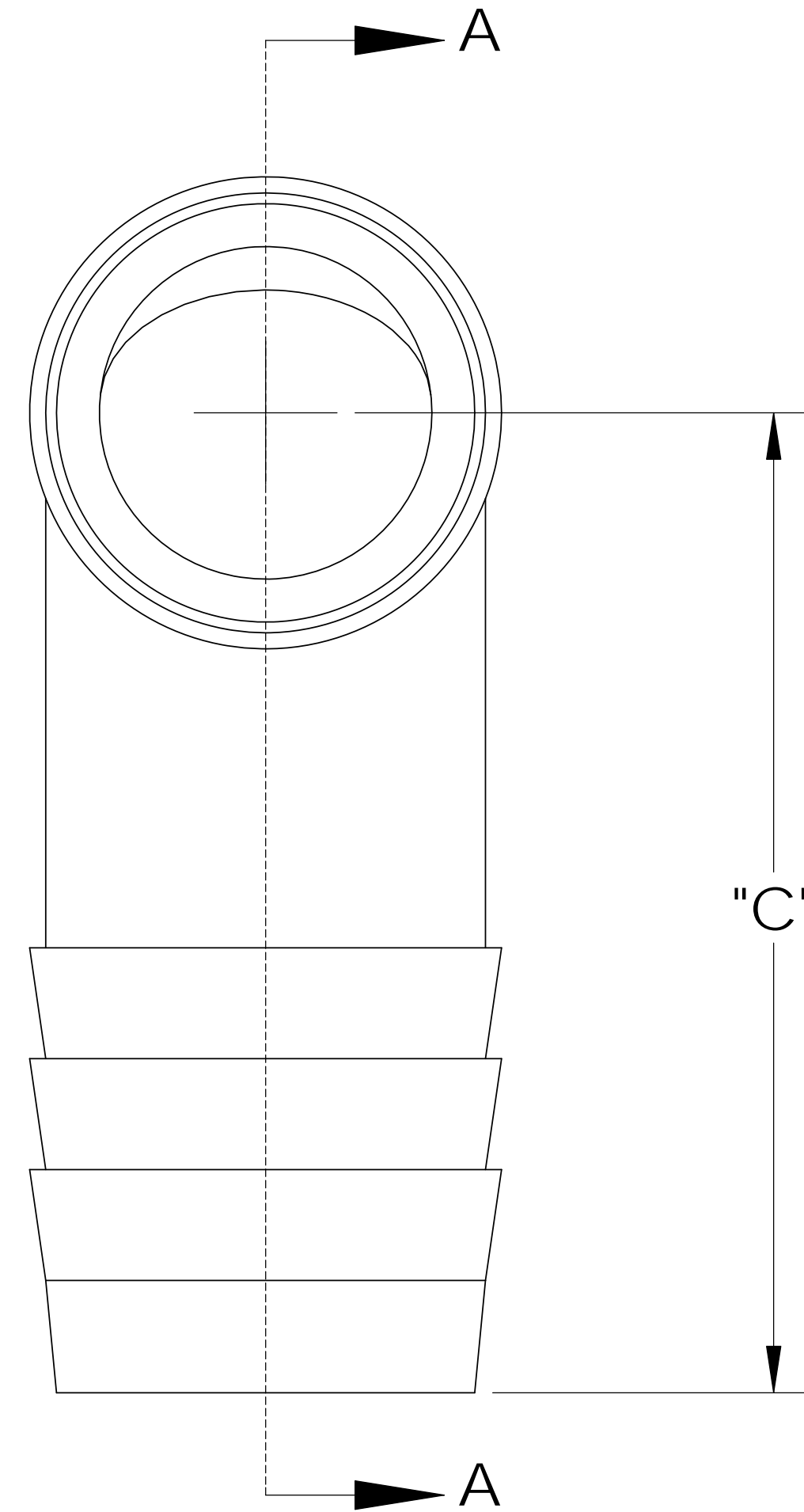

CATALOG NO.	DESCRIPTION	MATERIAL	DIM "A"	DIM "B"	DIM "C"	DIM "D"
TE201010-T/PP	5/8 X 5/8 PP	POLYPROPYLENE	.655	.460	1.36	.600
TE201010-T/P	5/8 X 5/8 P	POLYETHYLENE	.650	.455	1.32	.605
TE201010-T/N	5/8 X 5/8 N	NYLON	.660	.465	1.37	.615
TE201010-T/K	5/8 X 5/8 K	KYNAR	.660	.465	1.37	.615

SHOWN

NOTES:

- 1) POLYPROPYLENE HAS COLOR OPTIONS:  
BLACK = TE201010-T/PPB  
NATURAL = TE201010-T/PPN

**PROPRIETARY AND CONFIDENTIAL**  
THE INFORMATION CONTAINED IN THIS DRAWING IS THE SOLE PROPERTY OF THOGUS PRODUCTS COMPANY. ANY REPRODUCTION IN PART OR AS A WHOLE WITHOUT THE WRITTEN PERMISSION OF THOGUS PRODUCTS COMPANY IS PROHIBITED.

REV	WRO#	DESCRIPTION
D	95.00035	CONVERTED TO 3D FORMAT
HISTORY		

UNLESS OTHERWISE SPECIFIED:  
DIMENSIONS ARE IN INCHES  
TOLERANCES:  
ANGULAR:  $\pm 0.5^\circ$   
X.X =  $\pm 0.1$   
X.XX =  $\pm 0.05$   
X.XXX =  $\pm 0.015$   
REMOVE ALL SHARP EDGES AND BURRS  
BLEND ALL RADII TO 0.01IN  
INTERPRET GEOMETRIC TOLERANCING PER: ANSI Y 14.5 1994  
MATERIAL: PP, P, N, K  
FINISH: NA  
THIRD ANGLE PROJECTION:

	NAME	DATE
DRAWN	KDJ	10/25/10
CHECKED	JM	10/25/10
ENG APPR.		XX/XX/XX
MFG APPR.		XX/XX/XX
Q.A.		XX/XX/XX

**Thogus** You think it, we can make it...  
33490 PIN OAK, AVON LAKE, OH 44012

**TITLE:**  
BARB ELBOW, 5/8" X 5/8"

SIZE <b>B</b>	DWG. NO. TE201010-T	REV <b>F</b>
SCALE: 2:1	MASS:	SHEET 1 OF 1

DO NOT SCALE DRAWING